

ED. POM/KWH PDU

Per outlet current monitoring

Total kWh monitoring

Per outlet control

Daisy Chain

User Manual

EUROLAN

Safety Precautions

To avoid potential problems when using PDU:

- If the building has 3-phase AC power, ensure that the server and monitor are on the same phase. For best results, they should be on the same circuit.
- To avoid potentially fatal shock hazard and possible damage to equipment, test AC outlets at the server and monitor for proper polarity and grounding.
- To ensure the safety of network communication, it is recommended that the PDU be installed in a network firewall to prevent malicious attacks by hackers, which will affect the safety of power consumption.

Safety instructions

Read all the following safety guidelines to protect yourself and your PDU.

WARNING: All outlets of the PDU output high voltage. Necessary precautions should be taken.

WARNING: Do not push any objects through the openings of the PDU. Doing so may cause fire or electric shock by shorting out interior components.

WARNING: There is a possibility of severe electrical shock from either the live or neutral side of any of the power outlets or their wiring, even if one of the circuit breakers is disabled.

WARNING: The PDU is intended for indoor use only.

WARNING: To help protect the PDU from electrical power fluctuations, use a surge suppressor, line conditioner or uninterruptible power supply.

WARNING: Be sure that nothing rests on the cables of the PDU and that it is not located where it may be stepped on or tripped over.

WARNING: Do not spill food or liquids on the PDU. If it gets wet, disconnect the power immediately.

WARNING: Keep the PDU away from heat sources.

WARNING: One output can only be connected to a single device. Do not use extension cords to power multiple devices, so as not to damage the output relay due to the accumulation of inrush currents from multiple devices.

Rack mount safety considerations

When installing the PDU, make sure the following environmental specifications are met:

Elevated Operating Ambient Temperature: If the PDU is installed in a closed or multi-unit rack assembly, the operating ambient temperature of the rack environment may be greater than room ambient temperature. Therefore, consideration should be given to installing the equipment in an environment compatible with the manufacturer's maximum rated ambient temperature. See above.

Reduced Air Flow: Installation of the equipment in a rack should be such that the amount of air flow required for safe operation of

the equipment is not compromised.

Mechanical Loading: Mounting of the equipment in the rack should be such that a hazardous condition is not created due to uneven mechanical loading.

Circuit Overloading: Consideration should be given to the connection of the equipment to the supply circuit and the effect that overloading of circuits might have on over current protection and supply wiring. Appropriate consideration of equipment nameplate ratings should be used when addressing this concern.

Reliable Grounding: Reliable grounding of rack-mounted equipment should be maintained.

Particular attention should be given to supply connections other than direct connections to the branch circuit, such as power strips or extension cords.

Features and Benefits

The PDU is an Internet-ready power strip equipped with an intelligent current meter to indicate the total power consumption of the Power Distribution Unit (PDU). Each PDU includes PDU Utility software to monitor and manage multiple PDUs.

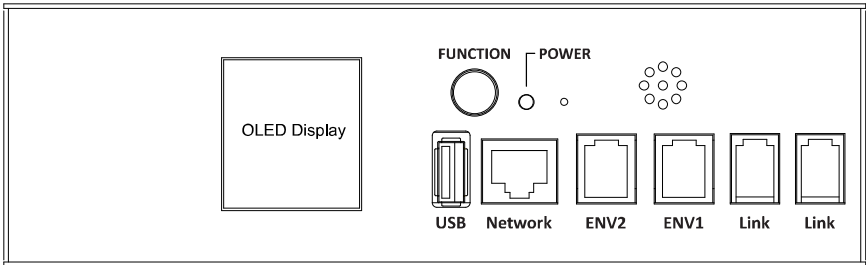

Functions	Description
Network	RJ45 Ethernet connection for the built-in web server.
Audible Alarm	<p>Holes for audible alarm.</p> <p>Warning- 1 beep in 1 second.</p> <p>Overload- 3 beeps in 1 second.</p> <p>Note: The audible alarm will keep beeping until the current gets back to normal and the current is lower than the threshold to 0.5 amps.</p>
Function Button (Master mode)	<ul style="list-style-type: none"> ● Press button then release it after 1 beeping; OLED shows temperature and humidity info. <p>In the temperature and humidity display</p>

mode, pressing the button again will switch the display of the branch current value and kWh in sequence.

If there is no action for about 5 seconds, it will return to the main display mode.

- Press button then release it after 1 beeping; OLED shows the PDU branch circuits' current, temperature, humidity and kWh in turn.
- Press button then release it after 2 beeping; OLED shows the PDU IP address
- Press button then release it after 3 beeping; OLED display is rotated 90 degrees counterclockwise.
- Press button then release it after 4 beeping; switch whether the PDU obtains IP through DHCP or fixed IP..
- Press button then release it after 6 beeping; reset PDU back to default setting.



After six beeps to return to factory settings, do not cut off the power when the long beep sounds until the power information is displayed, otherwise the system will be damaged and may not work normally.

- Press button then release it after 7 beeping; it can activate the daisy chain mode and set ID.
ID 0: PDU enter "Master" mode.
ID 1~3: PDU enter "Slave" mode

Function Button (Slave mode)	<ul style="list-style-type: none"> ● Keep pressing the function button, the ID number will change from 0-3. When the number shows 1, release the button, this PDU's daisy chain ID is 1. The rest and so on ● ID 0: PDU enter “Master” mode. ID 1~3: PDU enter “Slave” mode
OLED Display	<p>Display power information and IP address.</p> <p>Note: When an event occurs, the OLED Display will be highlighted.</p>
LED Indicator	<p>Power Status (red): Light means power is normal.</p>
ENV1 / ENV2	<p>RJ11 connection for optional accessory to measure temperature and humidity.</p>
LINK	<p>Through RJ22 cable , connecting master and slave.</p>
USB	<p>A wireless network dongle can be connected (must be used with the specified wireless network dongle)</p> <p>Note: Please set the wired network IP address as a fixed IP first, and then start the wireless network setting.</p>

Alarms and monitoring

The PDU delivers accurate, real-time global current monitoring of all connected devices via the onboard web interface or through the PDU Utility software. Users have the ability to set a current alarm threshold that, once exceeded, will cause the PDU to sound an alarm or send a notification message, or both.

Sequential power application

The PDU incorporates a sequential power application feature that prevents all power outlet receptacles from turning on at once, eliminating the potential of current surges that could render the equipment inoperable. Together with the global current monitoring, the sequential power application feature lets users safely install more equipment on existing power circuits without the worry of current overloads.

Features : **System**

- Built-in Web Server to Support Remote Power Management.
- Local LED Displays Amps, IP Address ,Temperature or Humidity
- Daily, Weekly, Monthly & Yearly Power Consumption Data
- 10/100 Base-T Ethernet Port
- IPv4 and IPv6 Support
- SNMP Control (v1,v2c,v3)
- Telnet, SSHv2 Encryption Support
- Radius Authentication
- User Account for Three Different Permissions Management System

- Alarm Notification via Email, SNMP, Syslog, LED or audible alarm
- SSLv3, TLS1.0,TLS1.1,TLS1.2 Support
- IP Address Filtering
- Max. of 100000 entries for each Power Consumption Data and Event Log
- Remote firmware Upgrade Support
- Alive of Heart Beat Trap Available.
- Definable Reset Button
- Fahrenheit and Celsius Switchable
- Export and Import PDU Configuration
- Supports cascading management.
- Support wireless network connection

Power Management

- True rms current measurement.
- Provide voltage, frequency, power factor, active power, apparent power and kwh information.
- Remote per outlet on/off power switching
- Remote per outlet current monitoring
- User defined alarm thresholds for warning and overload.
- User defined power on/off sequence time.
- Timed & scheduled on/off/reboot switching
- Alternative outlet restart mode: memorized previous status, always on or always off
- Ping-no-answer alarm
- Outlet action via pre-set event, including power event, environment event and receiving trap from other devices.
- Circuit breaker protection
- Free bundle management utility.

Getting Started

Before installing your PDU, refer to the following list to ensure you have all items that shipped with the PDU, as well as other items necessary for proper installation. The standard PDU package includes the following:

- Power Distribution Unit
- Rack mounting brackets
- Four retaining screws for each rack mounting bracket.

Daisy Chain Startup

This series supports the function of managing multiple PDUs with one IP. This series of PDUs can be used flexibly, and can be set as a master or a slave through the button.

The serial system function startup procedure is as follows:

1. After the PDU is powered on, press the Function key and release it after 7 beeps. The PDU will enter setting mode.

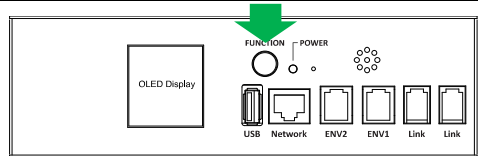

2. Set the PDU ID. Press the function key to switch the ID. When the number shows 1, release the button, this PDU's daisy chain ID is 1. The rest and so on.

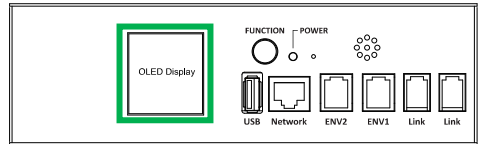

Note1: ID 0 : Master,
ID1~3 : Slave

Note2: slave ID cannot be set repeatedly, otherwise communication will not be possible.

Note3: OLED displays ID position as right drawing shown.

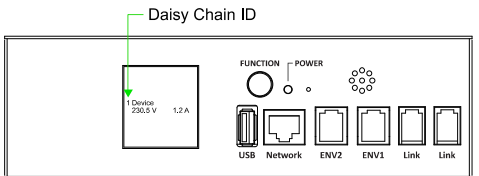

3. Connect master and slave by RJ22 cable.

Note: The Link ports are in parallel mode and can be connected arbitrarily.

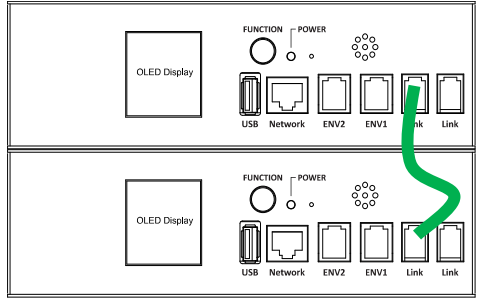

4. Go to Master unit's "Setting" page to start the communication of the slave unit.

Slave identity can be set here.

ID	System Identity	Identity	Enable
0	Master	<input type="text"/>	<input checked="" type="checkbox"/>
1	Slave-1	<input type="text"/>	<input type="checkbox"/>
2	Slave-2	<input type="text"/>	<input type="checkbox"/>
3	Slave-3	<input type="text"/>	<input type="checkbox"/>

Installation Instructions

This section will provide a quick instruction to install the PDU.

A) Elevated Operating Ambient - If installed in a closed or multi-unit rack assembly, the operating ambient temperature of the rack environment may be greater than room ambient. Therefore, consideration should be given to installing the equipment in an environment compatible with the maximum ambient temperature specified by the manufacturer.

B) Reduced Air Flow - Installation of the equipment in a rack should be such that the amount of air flow required for safe operation of the equipment is not compromised.

C) Mechanical Loading - Mounting of the equipment in the rack should be such that a hazardous condition is not achieved due to uneven mechanical loading.

D) Circuit Overloading - Consideration should be given to the connection of the equipment to the supply circuit and the effect that overloading of the circuits might have on over current protection and supply wiring. Appropriate consideration of equipment nameplate ratings should be used when addressing this concern.

E) Reliable Earthing - Reliable earthing of rack-mounted equipment should be maintained. Particular attention should be given to supply connections other than direct connections to the branch circuit (e.g. use of power strips)."

Diagram

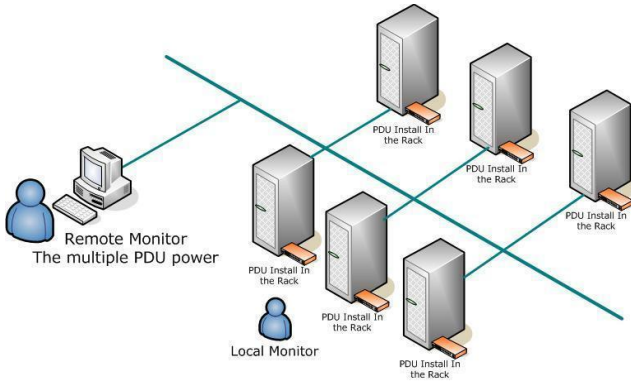

Hardware

1. Install mounting brackets.

The PDU comes with brackets for mounting in a rack. To mount the PDU into a rack performs the following procedure:

- 1.1 Attach the mounting brackets to the unit, using the four retaining screws provided for each of the brackets.

Horizontal:

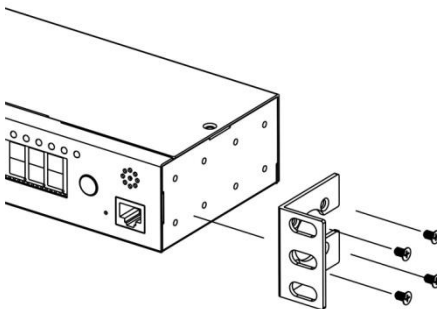

Vertical 1

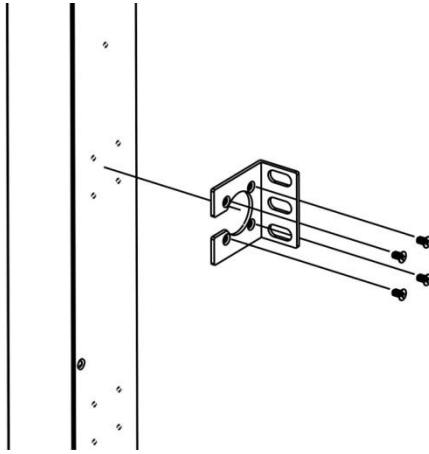

Vertical 2

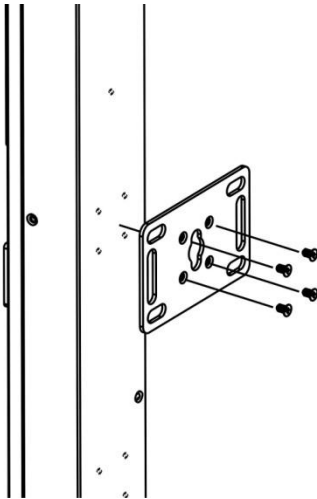

1.2 Choose a location for the brackets.

- 1.3 Align the mounting holes of brackets with the notched hole on the vertical rail and attach with the retaining screws.
2. Connect input and output power.
3. Connect Ethernet cable to the PDU.
4. Power on the PDU.

Web interface:

The default setting for the way to get IP address is DHCP. If PDU can not get the IP from DHCP server, the IP address will stay at **192.168.0.216**



Login Name:

Login Password:

Default ID: **snmp**

Default Password: **1234**

After login to web, user can check all operation instruction in web page of “Info.”



Information Overview

Display temperature and humidity information, Event log and Outlet status.

The screenshot displays the PDU monitoring interface with the following sections and callouts:

- Header:** PDU (left), EUIFOLAN (right)
- Navigation:** Information (selected), Management, Configuration
- Sub-Menu:** Overview (selected), Power, System, Event Log, Data Log, Chart
- Status:** Normal (with green checkmark icon)
- PDU Information:**
 - Total kWh: 0.351 kWh (Callout: Power Monitor)
 - Total PDU Current: 0 Amp
 - Temperature(1): N/A °C
 - Humidity(1): N/A % (Callout: ENV Monitor)
 - Temperature(2): N/A °C
 - Humidity(2): N/A %
- Event Log:**

Date	Time	Event
2021/01/15	02:08:11	Web user [snmp] logged in from 192.168.0.19
2021/01/15	02:07:11	DO1 has been turned open by (Ping No Response)
2021/01/15	02:02:11	DO1 has been turned open by (Ping No Response)
2021/01/15	01:57:11	DO1 has been turned open by (Ping No Response)
2021/01/15	01:52:11	DO1 has been turned open by (Ping No Response)

(Callout: Event List)
- Outlet Status:**

No.	Name	Status	Event	Ping	Schedule
1	OutletA	ON	<input checked="" type="checkbox"/>	<input checked="" type="checkbox"/>	<input checked="" type="checkbox"/>
2	OutletB	ON			

(Callout: Outlet Status)

Note:

Setting column

S: Schedule is set. PDU will execute the pre-set outlet action in specified time automatically.

P: Ping function is active. If the specified device stops ping response, PDU will execute the pre-set outlets action

E: PDU will execute the pre-set outlets' action according to event happen.

Power

All power information and each circuit current consumption

System

System information

Event Log

System memory can log up to 100000 entries.

Data Log

System memory can log up to 100000 entries.

The screenshot shows the PDU web interface. At the top right, there are links for 'Info' and 'Logout', and the 'EUROLAN' logo. Below the logo is a navigation bar with tabs for 'Information', 'Management', and 'Configuration'. Under 'Information', there are sub-tabs for 'Overview', 'Power', 'System', 'Event Log', 'Data Log', and 'Chart'. The 'Data Log' tab is selected. Below the navigation bar, the status is 'Normal' with a green checkmark, and the date/time is '2022/05/11 03:30:31'. The 'Data Log Filtering' section has a 'Filter' button. It includes a 'PDU' dropdown set to 'Master', a 'Data Log Time' section with 'Last' selected, and a date range from '2022/05/11 00:00:00' to '2022/05/11 23:59:59'. A callout box points to the 'Filter' button with the text: 'Select any PDU and time interval; press the Filter button, its data log will be displayed'. Below the filtering section is the 'Data Log' table.

Date	Time	kWh		V		Amp		Temp. C		Humidity %		
2022/05/11	03:19:48	17.475	12.412 11.152	109.45	109.35 109.13	0.00	0.00	0.00	N/A	N/A	N/A	N/A
2022/05/11	03:09:48	17.475	12.412 11.152	109.62	109.48 109.33	0.00	0.00	0.00	N/A	N/A	N/A	N/A
2022/05/11	02:59:48	17.475	12.412 11.152	109.83	109.71 109.63	0.00	0.00	0.00	N/A	N/A	N/A	N/A
2022/05/11	02:49:48	17.475	12.412 11.152	109.85	109.67 109.47	0.00	0.00	0.00	N/A	N/A	N/A	N/A
2022/05/11	02:39:48	17.475	12.412 11.152	109.97	109.83 109.76	0.00	0.00	0.00	N/A	N/A	N/A	N/A

Chart

Display history chart for voltage, current, temperature and humidity.

Info Logout
EUROLAN

PDU

Information Management Configuration

Overview Power System Event Log Data Log **Chart**

Status: Normal ✔

2022/05/11 03:31:02

Chart Filtering

PDU Filter

Master ▼

Data Log Time All Logs ▼

Last From

2022/05/11 00:00:00 ~ 2022/05/11 23:59:59

Select any PDU and time interval; press the Filter button, its chart will be displayed

Data Chart

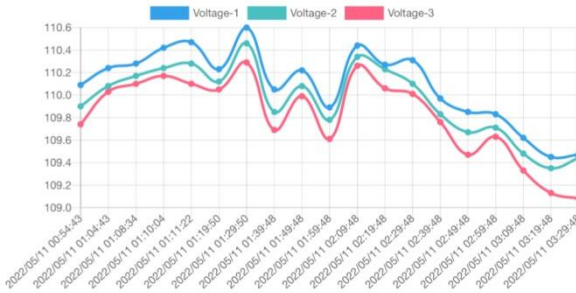

Chart: It can display voltage , amp , temperature and humidity history chart

Management

Control

1. Directly control outlet.
2. Set a number of outlets as a group to control them by one function button.

PDU

EUROLAN

Information **Management** Configuration
Control Schedule Ping Action Event Action Device Threshold



Status:  Normal

2022/03/29 05:42:59

Group Outlet Control

No.	<input type="checkbox"/>	Group	Outlet
01	<input type="checkbox"/>	NewGroup	OutletE(5) OutletF(6) OutletG(7) OutletH(8)

Outlet Control

No.	<input type="checkbox"/>	Outlet	Status	Task	Delay On(Sec)	Delay Off (Sec)
1	<input type="checkbox"/>	OutletA	 ON	Free	1	1
2	<input type="checkbox"/>	OutletB	 ON	Free	2	2
3	<input type="checkbox"/>	OutletC	 ON	Free	3	3
4	<input type="checkbox"/>	OutletD	 ON	Free	4	4
5	<input type="checkbox"/>	OutletE	 ON	Free	5	5
6	<input type="checkbox"/>	OutletF	 ON	Free	6	6
7	<input type="checkbox"/>	OutletG	 ON	Free	7	7
8	<input type="checkbox"/>	OutletH	 ON	Free	8	8

Schedule

Pre-set time to turn on or off the specified outlet

PDU

EUROLAN

Information **Management** Configuration

Control **Schedule** Ping Action Event Action Device Threshold

Status:  Normal

2022/03/29 05:45:09

Schedule Setting

Outlet
Outlet Action
Date(yyyy/mm/dd) Once
 Every
Time (hh:mm)

Schedule List

No.	<input type="checkbox"/> <u>Item</u>	<u>Date</u>	<u>Time</u>	<u>Action</u>	<u>Enable</u>
1	<input type="checkbox"/> OutletA	2022/03/29	10:00	OFF	<input checked="" type="checkbox"/>
2	<input type="checkbox"/> OutletB	Sunday	12:00	OFF/ON	<input checked="" type="checkbox"/>
3	<input type="checkbox"/> OutletC	Day	14:00	ON	<input checked="" type="checkbox"/>

1. Outlet A is scheduled to off at 10:00 on 2022/03/29.
2. Outlet B executes off/on at 12:00 every Sunday.
3. Outlet C executes on at 14:00 every day.

Ping Action

Ping-No-Answer power action

PDU

EUROLAN

Information **Management** Configuration

Control Schedule **Ping Action** Event Action Device Threshold

Status:  Normal

2022/03/29 06:06:18

Ping Action Setting

Outlet
IP Address
Response Time
Outlet Action

Ping Action List

No.	<input type="checkbox"/> Outlet	IP Address	Response Time	Action	Enable
01	<input type="checkbox"/> OutletA (1)	192.168.0.1	5 min(s)	OFF/ON	<input checked="" type="checkbox"/>
02	<input type="checkbox"/> OutletD (4)	192.168.0.100	15 min(s)	OFF	<input checked="" type="checkbox"/>

1. Ping 192.168.0.1, if there is no response within 5 minutes, Outlet A will OFF/ON
2. Ping 192.168.0.100, if there is no response within 15 minutes, Outlet D will OFF.

Automatically reboot the locked device by ping its IP

Event Action

Pre-set outlet action once the current, temperature or humidity over threshold

PDU

EUROLAN

Information Management Configuration
Control Schedule Ping Action **Event Action** Device Threshold

Status: ✔ Normal

2022/03/29 06:11:57

Event Action Setting

Event Device

ENV (1)

Receive Trap .1.3.6.1.4.1.

Outlet

Delay second(s)

Action

Action Type

Event List

No.	<input type="checkbox"/>	Event	Action	Enable
01	<input type="checkbox"/>	Receive Trap Trap .1.3.6.1.4.1.17420.1.6 From 192.168.0.1	OutletC (3) Delay 10 second(s) and turn OFF/ON	<input checked="" type="checkbox"/>
02	<input type="checkbox"/>	ENV (1) over the Temperature Overrun Occurs	OutletA (1) Delay 5 second(s) and turn OFF	<input checked="" type="checkbox"/>
03	<input type="checkbox"/>	Device over the warning threshold Occurs	OutletA (1) Delay 1 second(s) and turn OFF	<input checked="" type="checkbox"/>

1. Receive Trap message 1.3.6.1.4.1.17420.1.6, IP is 192.168.0.1; after 10 seconds, Outlet C will OFF/ON.

2. When ENV(1) the temperature exceeds the upper limit, after 5 seconds, Outlet A will "OFF"

3. When current over warning threshold, after 1 second, Outlet A will "OFF"..

Note:

Receive Trap OID equal to: User can input the private OID to trigger the specified outlet action.

Device

Outlets and circuits name, sequence on/off and outlet owner configuration

PDU

EUROLAN

Information **Management** Configuration

Control Schedule Ping Action Event Action **Device** Threshold

Status:  Normal

2022/03/29 06:18:25

Outlet Configuration

Apply

No.	Outlet Name	Delay On second(s)	Delay Off second(s)	After Restart	Owner
0	All Outlet	<input type="text"/>	<input type="text"/>	Last Status ▾	snmp ▾
1	<input type="text" value="OutletA"/>	<input type="text" value="1"/>	<input type="text" value="1"/>	Last Status ▾	snmp ▾
2	<input type="text" value="OutletB"/>	<input type="text" value="2"/>	<input type="text" value="2"/>	Last Status ▾	snmp ▾
3	<input type="text" value="OutletC"/>	<input type="text" value="3"/>	<input type="text" value="3"/>	Last Status ▾	snmp ▾
4	<input type="text" value="OutletD"/>	<input type="text" value="4"/>	<input type="text" value="4"/>	Last Status ▾	snmp ▾
5	<input type="text" value="OutletE"/>	<input type="text" value="5"/>	<input type="text" value="5"/>	Last Status ▾	snmp ▾
6	<input type="text" value="OutletF"/>	<input type="text" value="6"/>	<input type="text" value="6"/>	Last Status ▾	snmp ▾
7	<input type="text" value="OutletG"/>	<input type="text" value="7"/>	<input type="text" value="7"/>	Last Status ▾	snmp ▾
8	<input type="text" value="OutletH"/>	<input type="text" value="8"/>	<input type="text" value="8"/>	Last Status ▾	snmp ▾

Energy Configuration

Device Carbon Emission Rate

Apply

The max. length of outlet name is 36 characters

The max. time for delay on/off is 9999 seconds

After Restart:

Define the outlet action after power restart

Last Status: After power restart, outlets remain the same power status.

ON: Turn on outlets after power restart.

OFF: Turn off outlets after power restart.

Note:

After PDU is plugged into main power, PDU system will start to sequentially turn on the output socket according to the pre-set delay time in PDU web interface. The factory default setting for delay time is one second for each outlet; therefore the 8 ports PDU will take 8 seconds, 24 ports PDU will take 24 seconds to complete start-up procedure.

Before the sequence procedure is completed, if a PDU is unplugged from the power source, the outlets which are not turned on will be regarded as remaining at the power-off status. Next time the PDU is plugged into main power, these outlets will not be automatically turned on. These outlets can only be turned on by web interface.

Reset Accumulated Energy: Subtotal for energy (kWh). User can reset it to 0 and have PDU restart calculating.

Carbon Emission Rate: Users can check this parameter through power plant.

Threshold

Set threshold of current, temperature and humidity.

PDU

EUROLAN

Information **Management** Configuration
Control Schedule Ping Action Event Action Device **Threshold**

Status: Normal

2022/03/29 06:21:20

Device Threshold Configuration

No.	Device	Below	Warning	Overload	
01	Current	<input type="text" value="0"/>	<input type="text" value="12"/>	<input type="text" value="16"/>	<input type="button" value="Apply"/>
	Voltage	<input type="text" value="180"/>	<input type="text" value="250"/>	<input type="text" value="262"/>	<input type="button" value="Disable"/> <input type="button" value="v"/>

Set total current and voltage threshold

Circuit Threshold Configuration

No.	Circuit Name	Below (Amp)	Warning (Amp)	Overload (Amp)	
01	PDU1	<input type="text" value="0"/>	<input type="text" value="8"/>	<input type="text" value="10"/>	<input type="button" value="A"/>
02	PDU2	<input type="text" value="0"/>	<input type="text" value="8"/>	<input type="text" value="10"/>	
03	PDU3	<input type="text" value="0"/>	<input type="text" value="8"/>	<input type="text" value="10"/>	
04	PDU4	<input type="text" value="0"/>	<input type="text" value="8"/>	<input type="text" value="10"/>	
05	PDU5	<input type="text" value="0"/>	<input type="text" value="8"/>	<input type="text" value="10"/>	
06	PDU6	<input type="text" value="0"/>	<input type="text" value="8"/>	<input type="text" value="10"/>	
07	PDU7	<input type="text" value="0"/>	<input type="text" value="8"/>	<input type="text" value="10"/>	
08	PDU8	<input type="text" value="0"/>	<input type="text" value="8"/>	<input type="text" value="10"/>	

Set outlets threshold

ENV Threshold Configuration

No.	ENV	Temperature(°C)		Humidity(%)		<input type="button" value="Apply"/>
		Lower	Upper	Lower	Upper	
01	ENV 1	<input type="text" value="0"/>	<input type="text" value="99"/>	<input type="text" value="0"/>	<input type="text" value="99"/>	
02	ENV 2	<input type="text" value="0"/>	<input type="text" value="99"/>	<input type="text" value="0"/>	<input type="text" value="99"/>	

Set temperature and humidity threshold

Configuration

Network

IP address related configuration

The default setting for the way to get IP address is DHCP. If PDU can not get the IP from DHCP server, the IP address will stay at **192.168.0.216**

The max. length of host name is 36 characters

Security

Access setup for web, SSL, SSH and Telnet

Default login ID is **snmp** and password is **1234** for SSH and Telnet.

Note: SSH/Telnet command

```
-----
(1) Device / Phases
(2) Circuit
(3) Outlet
(4) Environment
(5) ATS
(6) Network
(7) About PDU
(8) Logout
>
```

- (1) Device / Phase : Display PDU Power information
- (2) Circuit: Display each circuit current.
- (3) Outlet: Display each outlet current and control it
- (4) Environment: Display temperature and humidity

information.

- (5) ATS: Display ATS information.
 - (6) Network: Display network information.
 - (7) About PDU: PDU system information.
-

User

Multiple users configuration

Note: Please set the email address to receive alert events.

Users can add up to 8 accounts.

Admin:	Full authority to monitor, control and configure PDU Default ID is snmp , password is 1234 (Access Information / Management / Configuration)
Power user:	Monitor PDU, control the specified outlets. No permission to configure PDU. Default Password: password (Access Information / Management)
View Only:	Monitor PDU only. No permission to control and configure PDU. Default Password: password (Access Information)

Mail

Mail server configuration

Send out alert message to pre-defined account when event occurs.

SNMP

Set the SNMP parameter

Support SNMPv1,v2 and v3

Time

Time by NTP or manually for schedule and log record

Time must be set properly; otherwise the schedule setting will not be performed correctly.

Radius

Advanced authentication

System supports the Remote Authentication Dial-in User Service protocol. (RADIUS). It provides a centralized network protocol to enable remote authentication and authorization.

Log

Log setup

Export	Export events and data log in text format. Set the date to mail kWh usage information.
Syslog	Sent event log to the specified syslog server.
Data log	Set the interval of log time.
Heartbeat Trap	Send trap continuously to the specified IP to indicate PDU is alive.
Event Log	Check the box to enable to log the specified event

System

Configure file export and import, firmware upgrade, reset functions.

System	Export system configuration.
--------	------------------------------

	Import system configuration from export file.
Firmware Upgrade	Update: Keep all configurations after complete firmware upgrade. Update and Reset: Reset all configurations back to default after complete firmware upgrade.
Reset System	Restart network system through web.
Temperature Scale	Switch temperature unit between Celsius and Fahrenheit
Hardware Reset Button Definition	Define reset action. The reset procedure is to press and hold the key in the front panel of PDU, release it after hearing 6 beeping.
Daisy Chain Configuration	Enable the communication function between mater and slave units. Set the slave name

Status: Normal 

2022/05/11 03:32:45

Language / 語言

English 

System Configuration

Configuration

Export

Export

Configuration

Import

 選擇檔案 尚未選擇檔案

Upload

Update

Firmware Upgrade

Firmware Upload

 選擇檔案 尚未選擇檔案

Upload

Update

Update and Reset

Reset System

Apply

Reset All Setting Back to Factory Default

Reset All Setting Back to Factory Default Except the IP Address

Hardware Reset Button Definition

Apply

Reset All Setting Back to Factory Default

Reset Administrator's Password to Default Only

Disable (Please note if you forget the password, you can not recover the system anymore!)

Temperature Scale

Apply

Fahrenheit °F

Celsius °C

Auto Logout

10  minut

Apply

Daisy Chain Configuration

Apply

ID	System Identity	Identity	Enable
0	Master	<input type="text"/>	<input type="checkbox"/>
1	Slave-1	<input type="text"/>	<input checked="" type="checkbox"/>
2	Slave-2	<input type="text"/>	<input type="checkbox"/>
3	Slave-3	<input type="text"/>	<input type="checkbox"/>

Enable the communication function between mater and slave units. Set the slave name